

DS/EN 1997-1 DK NA:2021

National Annex to

Eurocode 7: Geotechnical design – Part 1: General rules

Foreword

This National Annex is a revision of DS/EN 1997-1 DK NA:2020 and supersedes the 2020 version as from 1 January 2021.

The reason for the changes is that, according to DS/EN 1990 DK NA, all foundations have until now been assigned to CC2, regardless of whether the construction work on the foundation was assigned to CC1.

Consequently, modifications to this National Annex include Annex A.1, where the text:

- *The low consequence class, CC1, is not applied for geotechnical structures* has been deleted.
- Instead, the following text has been added: *Low consequence class, CC1: $K_{FI} = 1,0$.*

Notes for tables are normative, while other notes are informative.

This NA specifies the conditions for the implementation in Denmark of DS/EN 1997-1 for construction works in conformity with the Danish Building Regulations. Other parties, for whom the Danish Building Regulations are not applicable, can put this NA into effect by referring hereto.

This NA includes:

- National choices and an overview of all clauses where national choices are allowed;
- Descriptions of the national choices;
- Complementary (non-contradictory) information which may assist the user of DS/EN 1997-1;
- Informative Annexes which replace the corresponding informative Annexes of DS/EN 1997-1, or which have been made normative in Denmark.

Addenda and an overview of all National Annexes can be accessed at <https://www.ds.dk/da/fagomraader/byggeri-og-anlaeg/eurocodes/nationale-annekser/gaeldende>

National choices and an overview of all clauses where national choices are allowed;

Clause	Subject	Choice
2.1(8)P	Design requirements The manner in which these minimum requirements are complied with may be given in the National Annex.	The national minimum requirements are given in Annex C, D, K and L of this National Annex.
2.4.6.1(4)P	Design values of actions The values of the partial factors may be set by the National Annex.	Values of the partial factors are given in clauses A.2, A.3, A.4 and A.6 of this National Annex.
2.4.6.2(2)P	Design values of geotechnical parameters The values of the partial factors may be set by the National Annex.	Values of the partial factors are given in clauses A.2, A.3, A.4 and A.6 of this National Annex.
2.4.7.1(2)P	Ultimate limit states – General The values of the partial factors may be set by the National Annex.	Values of the partial factors are given in clauses A.2, A.3.1, A.4 and A.6 of this National Annex.
2.4.7.1(3)	Ultimate limit states – General The values of the partial factors may be set by the National Annex.	Values of the partial factors are given in clause A.7 of this National Annex.
2.4.7.1(4)	Ultimate limit states – General The values of the partial factors may be set by the National Annex.	Values of the partial factors are given in clauses A.2, A.3.1, A.4 and A.6 of this National Annex.
2.4.7.1(5)	Ultimate limit states – General The values of the partial factors may be set by the National Annex.	Values of the partial factors are given in clause A.3.1 of this National Annex.
2.4.7.1(6)	Ultimate limit states – General The values of the partial factors may be set by the National Annex.	Values of the partial factors are given in clause A.3.1 of this National Annex.

Clause	Subject	Choice
2.4.7.2(2)P	<p>Verification of static equilibrium (EQU) The values of the partial factors may be set by the National Annex.</p>	Values of the partial factors are given in clause A.2 of this National Annex.
2.4.7.3.2(3)P	<p>Design effects of actions The values of the partial factors may be set by the National Annex.</p>	Values of the partial factors are given in clause A.3.1 of this National Annex.
2.4.7.3.3(2)P	<p>Design resistances The values of the partial factors may be set by the National Annex.</p>	Values of the partial factors are given in clause A.3.1 of this National Annex.
2.4.7.3.4.1(P)	<p>Design approaches – General NOTE 1 – Application of equations (2.6) and (2.7) and the particular design approach to be used may be given in the National Annex.</p>	NOTE 1 – Application of equations (2.6) and (2.7) refers in DK to design approach 3.
2.4.7.4(2)	<p>Verification procedure and partial factors for uplift (2) Additional resistance to uplift may also be treated as a stabilising permanent vertical action ($G_{stb;d}$) The paragraph corresponds to the content of 10.2(2)P as amended by corrigendum DS/EN 1997-1/AC:2010 and should be as follows: (2) If allowed by the National Annex, resistance to uplift by friction or anchor forces may also be treated as a stabilising permanent vertical action ($G_{stb;d}$)</p>	Treating resistance to uplift by friction or anchor forces as a stabilising permanent vertical action ($G_{stb;d}$) is not allowed.
2.4.7.4(3)P	<p>Verification procedure and partial factors for uplift The values of the partial factors may be set by the National Annex.</p>	Values of the partial factors are given in clause A.4 of this National Annex.

Clause	Subject	Choice
2.4.7.5(2)P	Verification of resistance to failure by heave due to seepage of water in the ground (HYD) The values of the partial factors may be set by the National Annex.	Values of the partial factors are given in clause A.5 of this National Annex.
2.4.8(2)	Serviceability limit states The values of the partial factors may be set by the National Annex.	Values of the partial factors are given in clause A.7 of this National Annex.
2.4.9(1)P	Limiting values for foundation displacements The permitted foundation displacements may be set by the National Annex.	Permitted foundation displacements are given in Annex H and the National Appendix to Annex H.
2.5(1)	Design by prescriptive measures Reference to such conventional and generally conservative rules may be set by the National Annex.	Conventional and generally conservative rules are given in Annexes C, D, K and L of this National Annex.
7.6.2.2(8)P	Ultimate compressive resistance from static load tests The values of the correlation factors may be set by the National Annex.	Values of the correlation factors are given in clause A.3.2 of this National Annex.
7.6.2.2(14)P	Ultimate compressive resistance from static load tests The values of the partial factors may be set by the National Annex.	Values of the partial factors are given in clause A.3.1 of this National Annex.
7.6.2.3(4)P	Ultimate compressive resistance from ground test results The values of the partial factors may be set by the National Annex.	Values of the partial factors are given in clause A.3.1 of this National Annex.
7.6.2.3(5)P	Ultimate compressive resistance from ground test results The values of the correlation factors may be set by the National Annex.	Values of the correlation factors are given in clause A.3.2 of this National Annex.

Clause	Subject	Choice
7.6.2.3(8)	<p>Ultimate compressive resistance from ground test results If this alternative procedure is applied, the values of the partial factors γ_b and γ_s recommended in Annex A may need to be corrected by a model factor larger than 1,0. The value of the model factor may be set by the National Annex.</p>	A model factor is not applied in DK.
7.6.2.4(4)P	<p>Ultimate compressive resistance from dynamic impact tests The values of the partial factors and correlation factors may be set by the National Annex.</p>	Values of the partial factors are given in clauses A.3.1 and A.3.2 of this National Annex.
7.6.3.2(2)P	<p>Ultimate tensile resistance from pile load tests The values of the partial factors may be set by the National Annex.</p>	Values of the partial factors are given in clause A.3.1 of this National Annex.
7.6.3.2(5)P	<p>Ultimate tensile resistance from pile load tests The values of the correlation factors may be set by the National Annex.</p>	Values of the correlation factors are given in clause A.3.2 of this National Annex.
7.6.3.3(3)P	<p>Ultimate tensile resistance from ground test results The values of the partial factors may be set by the National Annex.</p>	Values of the partial factors are given in clause A.3.1 of this National Annex.
7.6.3.3(4)P	<p>Ultimate tensile resistance from ground test results The values of the correlation factors may be set by the National Annex.</p>	Values of the correlation factors are given in clause A.3.2 of this National Annex.
7.6.3.3(6)	<p>Ultimate tensile resistance from ground test results If this alternative procedure is applied, the values of the partial factor $\gamma_{s,t}$ recommended in Annex A may need to be corrected by a model factor larger than 1,0. The value of the model factor may be set by the National Annex.</p>	The model factor applied in DK is taken as 1,0 where design is based on the analytical method for determining the bearing resistance specified in Annex L of this National Annex.

Clause	Subject	Choice
8.4(6)P	Design and construction considerations The method of determining the necessary free length may be set by the National Annex.	For UPL, requirements and guidelines for determining the free length are given in Annex A, clause A.4 8(P) and the related NOTE 1 of this National Annex.
8.4(7)P	Design and construction considerations The criteria for when it is necessary to check the group effect may be set by the National Annex.	The criteria for checking the group effect are given in clause A.4, (7)P and (8)P, of this National Annex. The requirements for group testing are specified in DS/EN ISO 22477-5:2018, clause 6.7.
8.5.1(1)P NOTE 1	Limit state design of anchors – General The value of γ_{Serv} may be set by the National Annex.	The value of γ_{Serv} is given in clause A.6, Table A.6-1, of this National Annex.
8.5.1(1)P NOTE 3	Limit state design of anchors – General In Section 8 it is assumed that all partial factors and correlation factors for serviceability limit states are 1 unless symbols are specifically included. The values for additional partial factors and correlation factors for serviceability limit states may be set by the National Annex.	The values of partial factors and correlation factors for serviceability and accidental limit states verification are given in clause A.7 of this National Annex.
8.5.1(2)P NOTE 1	Limit state design of anchors – General The National Annex may state whether a separate evaluation of the serviceability limit state of the anchor is required.	A separate evaluation of the serviceability limit state of the anchor is not required as the acceptance test is related to $E_{\text{ULS;d}}$ cf (8.13); the effect of the prestress force under serviceability limit state conditions is therefore taken into account.
8.5.1(2)P NOTE 2	Limit state design of anchors – General The National Annex may state whether the ultimate limit state and the serviceability limit state are to be verified separately or by a combined procedure.	The acceptance test is related to $E_{\text{ULS;d}}$, cf (8.13); the effect of the prestress force under serviceability limit state conditions is therefore taken into account.

Clause	Subject	Choice
8.5.2(1)P	<p>Geotechnical ultimate limit state resistance The test method to be used to determine the measured resistance and the number of tests n may be set by the National Annex.</p>	The test method applied and the number of tests n are given in clause A.6, Table A.6-2 NA, of this National Annex.
8.5.2(2)P	<p>Geotechnical ultimate limit state resistance The limiting value of the creep rate (α_{ULS}) or load loss ($k_{l;\text{ULS}}$) may be set by the National Annex, which may specify the use of an asymptote to the creep rate versus load curve instead of a specified value for α_{ULS}. Recommended values for persistent and transient situations are given in Table A.21.</p>	The definition of failure and limiting values of creep rates are given in clause A.6, Table A.6-3 NA, of this National Annex.
8.5.2(3)P NOTE 1	<p>Geotechnical ultimate limit state resistance The value of the correlation factor ξ_{ULS} may be set by the National Annex. Recommended values for persistent and transient situations are given in Table A.20.</p>	The value of the correlation factor ξ_{ULS} is given in clause A.6, Table A.6-2 NA, of this National Annex.
8.5.2(3)P NOTE 2	<p>Geotechnical ultimate limit state resistance The minimum number of investigation or suitability tests n to be carried out to determine $(R_{\text{ULS};m})_{\text{min}}$ may be set by the National Annex. Recommended values for persistent and transient situations are given in Table A.20.</p>	The minimum number of investigation or suitability tests to be carried out to determine $(R_{\text{ULS};m})_{\text{min}}$ are given in clause A.6, Table A.6-2 NA, of this National Annex.
8.5.2(5)P	<p>Geotechnical ultimate limit state resistance The value of the partial factor $\gamma_{a;\text{ULS}}$ may be set by the National Annex. Recommended values for persistent and transient situations are given in Table A.19.</p>	The value of the partial factor $\gamma_{a;\text{ULS}}$ for persistent and transient situations are given in clause A.3, Table A.3-2 NA, for GEO and clause A.4, Table A.4-1 NA for UPL in this National Annex.

Clause	Subject	Choice
8.5.3(1)P	<p>Geotechnical serviceability limit state resistance</p> <p>The test method to be used to determine the measured resistance and the number of tests n may be set in the National Annex.</p>	The method to determine P_c is given in DS/EN ISO 22477-5:2018, Annex C. There is, however, no requirement to determine P_c .
8.5.3(2)P	<p>Geotechnical serviceability limit state resistance</p> <p>The value of the creep rate (α_{SLS}), the load loss ($k_{l,SLS}$) or P_c may be set by the National Annex. Recommended values are given in Table A.21.</p>	No value is given for the creep rate (α_{SLS}), the load loss ($k_{l,SLS}$), or P_c in the National Annex as test method 1 shall be used, cf DS/EN ISO 22477-5:2018.
8.5.3(3)P	<p>Geotechnical serviceability limit state resistance</p> <p>The minimum number of investigation or suitability tests n to be carried out to determine $(R_{SLS;m})_{min}$ may be set by the National Annex. Recommended values are given in Table A.20.</p>	There is no requirement to determine $(R_{SLS;m})_{min}$.
8.5.3(4)P	<p>Geotechnical serviceability limit state resistance</p> <p>The value of the partial factor $\gamma_{a,SLS}$ may be set by the National Annex. The recommended values are given in Table A.20.</p>	$\gamma_{a,SLS}$ is not relevant, as test method 1 shall be applied.
8.6.2(2)P NOTE 1	<p>Testing of anchors - Acceptance tests</p> <p>The value of the partial factors $\gamma_{a,acc;ULS}$ and $\gamma_{a,acc;SLS}$ may be set by the National Annex. Recommended values of $\gamma_{a,acc;ULS}$ for persistent and transient situations and for $\gamma_{a,acc;SLS}$ are given in Table A.20.</p>	The value of the partial factor $\gamma_{a,acc;ULS}$ is given in clause A.3.1, Table A.3-2 NA, clause A.4, Table A.4-1 NA and in clause A.6, Table A.6-2 NA of this National Annex. $\gamma_{a,acc;SLS}$ is not relevant, as test method 1 shall be applied.
8.6.2(2)P NOTE 2	<p>Testing of anchors - Acceptance tests</p> <p>The National Annex may state whether the proof load in an acceptance test is to be related to the ultimate limit state design force (8.13) or to $F_{Serv;k}$ (8.14).</p>	The acceptance test is to be related to the ultimate limit state design force (8.13).

Clause	Subject	Choice
8.6.2(3)P NOTE 1	<p>Testing of anchors - Acceptance tests The limiting values of creep rate/load loss at proof load may be set by the National Annex. Recommended values for persistent and transient situations are given in Table A.21.</p>	<p>The limiting values of creep rates at proof load are given in clause A.6, Table A.6-3 NA, of this National Annex. These values are differentiated according to the observation time depending on the type of soil, see DS/EN ISO 22477-5:2018, 8.4.3.</p>
8.6.2(3)P NOTE 2	<p>Testing of anchors - Acceptance tests The requirement to check the creep rate/load loss at other specified loads that are less than the proof load is optional and may be set by the National Annex. No recommended values are given.</p>	<p>There is no requirement to check the creep rate/load loss at other specified loads that are less than the proof load.</p>
10.2(2)P	<p>Failure by uplift The third sentence: "Resistance to uplift by friction or anchor forces may also be treated as a stabilising permanent vertical action ($G_{stb;d}$)" is replaced by "If allowed by the National Annex, resistance to uplift by friction or anchor forces may also be treated as a stabilising permanent vertical action ($G_{stb;d}$)." The correction appears from corrigendum DS/EN 1997-1/AC:2010, but is incorrectly stated for 10.2(3)</p>	<p>Treating resistance to uplift by friction or anchor forces as a stabilising permanent vertical action ($G_{stb;d}$) is not allowed.</p>

Clause	Subject	Choice
10.2(3)	<p>Failure by uplift</p> <p>Clause 23 in Corrigendum DS/EN 1997-1/AC:2010 states the modifications to subclause 10.2 as follows (quotation)</p> <p><i>Part (3):</i></p> <p><i>Replace the entire 1st paragraph with the following:</i></p> <p>"If allowed by the National Annex, resistance to uplift by friction or anchor forces may also be treated as a stabilising permanent vertical action ($G_{stb;d}$).</p> <p>NOTE – The values of the partial factors may be set by the National Annex."</p>	<p>The modification (entered by CEN) refers incorrectly to clause 10.2(3) but should refer to clause 10.2(2)P.</p> <p>The original text:</p> <p>"(3) In simple cases, the check of equation (2.8) in terms of forces may be replaced by a check in terms of total stresses and pore-water pressures." is maintained.</p>
11.5.1(1)P	<p>Stability analysis for slopes</p> <p>The values of the partial factors may be set by the National Annex.</p>	<p>Values of the partial factors are given in clause A.3.1 of this National Annex.</p>
A.2	<p>Partial factors for equilibrium limit state (EQU) verification</p>	<p>Partial factors and consequence factors are given in clause A.2 of this National Annex.</p>
A.3.1	<p>Partial factors for actions (γ_F) or the effects of actions (γ_E)</p>	<p>Partial factors and consequence factors are given in clause A.3.1 of this National Annex.</p>
A.3.2	<p>Partial factors for soil parameters (γ_M)</p>	<p>Partial factors are given in clause A.3.1 of this National Annex.</p>
A.3.3.1	<p>Partial resistance factors for spread foundations</p>	<p>Partial resistance factors (γ_R) for spread foundations are not used in DK, cf clause A.3.1 of this National Annex.</p>
A.3.3.2	<p>Partial resistance factors for pile foundations</p>	<p>Partial resistance factors for pile foundations are given in clause A.3.1 of this National Annex.</p>
A.3.3.3	<p>Correlation factors for pile foundations</p>	<p>Correlation factors for pile foundations are given in clause A.3.2 of this National Annex.</p>

Clause	Subject	Choice
A.3.3.5	Partial resistance factors (γ_R) for retaining structures	Partial resistance factors (γ_R) for retaining structures are not used in DK, cf clause A.3.1 of this National Annex.
A.3.3.6	Partial resistance factors (γ_R) for slopes and overall stability	Partial resistance factors (γ_R) for slopes and overall stability are not used in DK, cf clause A.3.1 of this National Annex.
A.4	Partial factors for uplift limit state (UPL) verification	Partial factors and consequence factors for uplift limit state (UPL) verification are given in clause A.4 of this National Annex.
A.5	Partial factors for hydraulic heave limit state (HYD) verification	Partial factors for hydraulic heave limit state (HYD) verification in DK are those applied for uplift limit state (UPL) verification, cf clause A.5 of this National Annex.
A.6	Partial factors, correlation factors, limiting criteria for ultimate and serviceability limit states as well as number of investigation or suitability tests for anchors	Partial factors, correlation factors, limiting criteria for ultimate and serviceability limit states as well as number of investigation or suitability tests for anchors are given in clause A.6 of this National Annex.

Complementary (non-contradictory) information

Clause	Subject	Choice
2.4.7.3.4.4	Design approach 3	NOTE 2 applies in DK also for the determination of earth pressure.
7.6.2.2(4)P	Ultimate compressive resistance from static load tests	The specifications are not applicable in DK.
7.6.2.3(4)P	Ultimate compressive resistance from ground test results	The specifications are not applicable in DK.
A.7	Partial factors, correlation factors and model factors for serviceability and accidental limit states verification.	Partial factors, correlation factors and model factors for serviceability and accidental limit states verification are given in clause A.7 of this National Annex.

Annex	Subject	Choice
C	Earth pressure	A new National Annex addressing some principal Danish conditions concerning earth and water pressure on walls.
D	Spread foundations. Analytical method for bearing resistance calculation	Bearing resistance equations in combination with the partial factors for spread foundations securing the safety required in Denmark are given in Annex D of this National Annex.
H	Limiting values of structural deformation and foundation displacement	Complementary information regarding conventional building structures is given in the Appendix to Annex H.
K	Special conditions for geotechnical investigations and parameters	Particular Danish conditions for geotechnical investigations are given in Annex K of this National Annex.
L	Pile foundations. Analytical method for bearing resistance calculation	An analytical method for determining the bearing resistance of piles is given in Annex L of this National Annex.

Annexes A, C, D, K and L are normative. Annex H is informative.

National choices

Annex A – normative

Partial and correlation factors for ultimate limit states and serviceability limit states

A.1 Partial factors and correlation factors

(1)P The partial factors (γ) for ultimate limit states and serviceability limit states in persistent and transient situations and the correlation factors (ξ) for pile foundations and anchorages in all design situations, are given in this Annex.

(2)P The partial factors for soil parameters (γ_M) and resistance (γ_R) as well as the correlation factors (ξ) for pile foundations and anchorages are stated for design situations, where the safety evaluation shall be performed using the lower design values. Where the safety evaluation is to be performed using the upper design values, reciprocal values of the partial factors and correlation factors given shall be applied.

NOTE – The partial factors apply to soil parameters determined taking account of the considerations specified in DS/EN 1997-1, clause 3.3.6(1)P.

The consequence factor, K_{FI} , depends on the consequence class:

High consequence class	CC3:	$K_{FI} = 1,1$
Medium consequence class	CC2:	$K_{FI} = 1,0$
Low consequence class	CC1:	$K_{FI} = 1,0$.

Regarding the load combination factor, ψ_0 , see DS/EN 1990 DK NA.

A.2 Partial factors for equilibrium limit state (EQU) verification

(1)P Partial factors (γ) and consequence factors (K_{FI}) are given in Table A.2-1 NA.

(2)P For equilibrium limit state (EQU) verification, the partial factors for actions (γ_F) and for soil parameters (M) stated in Table A.2-1 shall be used.

Table A.2-1 NA Partial factors for EQU design

Partial factors for actions			γ_F	
Permanent action	Self-weight, in general ¹⁾	Unfavourable	$\gamma_{G;dst}$	$1,1 \cdot K_{FI}$
		Favourable	$\gamma_{G;stb}$	0,9
	Self-weight of the ground and (ground) water, geotechnical structures ²⁾	Unfavourable	$\gamma_{G;dst}$	$1,1 \cdot K_{FI}$
		Favourable	$\gamma_{G;stb}$	0,9
Variable action	Leading	Unfavourable	$\gamma_{Q,1}$	$1,5 \cdot K_{FI}$
	Accompanying	Unfavourable	$\gamma_{Q,i}$	$1,5 \cdot \psi_0 \cdot K_{FI}$
Traffic loads Bridges ³⁾	Leading	Unfavourable	$\gamma_{Q,1}$	$1,4 \cdot K_{FI}^{5)}$
	Not leading	Unfavourable	$\gamma_{Q,i}$	$1,4 \cdot \psi_0 \cdot K_{FI}$
Partial factors for soil parameters			γ_M	
Angle of shearing resistance ⁷⁾			γ_ϕ	1,2
Effective cohesion			$\gamma_{c'}$	1,2
Undrained shear strength			γ_{cu}	1,8
Unconfined strength			γ_q	1,8
Weight density			γ_γ	1,0

- 1) Structural actions, which include all types of permanent self-weight: cf. clause 2.1 in DS/EN 1991-1-1.
- 2) Actions from self-weight of the ground and (ground) water interacting with the geotechnical structure as geotechnical actions, cf clause 1.5.2.1 in DS/EN 1997-1, and clause A.3.1(2)P, NOTE, in this National Annex
- 3) For traffic loads on civil engineering structures (e.g. railway and road dams, quays etc.), the partial factors for bridges apply
- 5) For heavy carriages on rails (SW/2): $1,2 \cdot K_{FI}$ and 1,2 respectively
- 7) The partial factor shall be applied to $\tan \phi$

A.3 Partial factors for structural (STR) and geotechnical (GEO) limit states verification

A.3.1 Partial factors for actions (F) or the effects of actions (E), for soil parameters (M) and for resistance (R)

(1)P Partial factors (γ) and consequence factors (K_{FI}) are given in Table A.3-1 NA for spread foundations, earth pressures and stability, and in Table A.3-2 NA for piles and anchors.

(2)P For structural (STR) and geotechnical (GEO) limit states verification, design approach 3 shall be used with:

Combination: (A1* or A2[†]) "+" M2 "+" R3

and the partial factors for actions (γ_F), for soil parameters (γ_M) and for resistance (γ_R) according to Tables A.3-1 NA and A.3-2 NA, as well as a factor (γ_0) to the partial factor for strength parameters and resistances of structural materials, cf DS/EN 1992 – DS/EN 1996 and DS/EN 1999.

NOTE – Partial factors as stated for "Self-weight, in general" are to be assigned to structural actions referred to geotechnical actions.

(3) The load combinations 1-5 in Tables A.3-1 NA and A.3-2 NA refer to all types of geotechnical structures where the load constitutes combinations of structural actions, earth pressures and/or water pressures. The investigations refer to the equations:

- (2.6a) with the design value of the load effect $E_d = E\{\gamma_F F_{rep}; X_k/\gamma_M; a_d\}$
- (2.7a) with the design value of the resistance to an action $R_d = R\{\gamma_F F_{rep}; X_k/\gamma_M; a_d\}$
- (2.7b) with the design value of the resistance to an action $R_d = R\{\gamma_F F_{rep}; X_k; a_d\}/\gamma_R$

NOTE 1 – In all 5 load combinations the partial factors for the strength parameters and for the resistances of the structural materials related to DS/EN 1992 – DS/EN 1996 and DS/EN 1999, are to be factored by γ_0 . For the soil parameters and resistances, γ_0 is incorporated in the partial factors γ_M and γ_R .

NOTE 2 – Load combination 5 is to be used for verification of STR for structural materials in geotechnical structures. In this verification the partial factors for the structural materials as stated in the respective structural Eurocodes are to be factored by γ_0 . The partial factors for soil parameters and resistances are to be 1,0 in load combination 5. This load combination will typically be critical for geotechnical structures, where water pressures constitute the essential part of the actions.

(4)P The partial factors for spread foundations and pile foundations ensure that the required Danish safety is attained when the equations for resistance given in Annex D and Annex L are applied.

(5)P Partial factors for piles and anchors shall be used in combination with the correlation factors specified in clause A.3.2.

(6)P For Geotechnical Category 1, the partial factors given for soil parameters and resistances shall be multiplied by a model factor $\gamma_s = 1,25$.

(7)P For excavation supports, temporary excavations and other geotechnical structures under construction, partial factors shall be used with values taken as $(\gamma_M)^\alpha$ and $(\gamma_R)^\alpha$, where α is a number for which the following applies: $0 \leq \alpha \leq 1$.

(8)P Where failure involves the risk of serious consequences or damage to third party property, or will have considerable social consequences, partial factors corresponding to $\alpha = 1,0$ are to be used. Structures in CC3 shall be designed with $\alpha = 1,0$.

NOTE – Third party property includes surrounding land, buildings and any kind of utility lines as well as areas with road and rail traffic.

(9) Where failure of geotechnical structures during construction is not covered by 8(P), partial factors corresponding to $\alpha = 0,5$, or - if the circumstances permit it, corresponding to α values closer to $\alpha = 0$ (partial factor 1,0) may be used.

Table A. 3-1 NA Partial factors for STR/GEO design: Spread foundations, earth pressure and stability

Design approach			3					
Limit state			STR/GEO				STR	
Combination of actions			1	2	3	4	5	
Partial factors for actions see equation (2.6a) ⁸⁾			γ_F	A1* or A2[†]				
Permanent action ⁶⁾	Self-weight, in general ¹⁾	Unfavourable	$\gamma_{G;sup}$	$1,2 \cdot K_{FI}^{4)}$	$1,0 \cdot K_{FI}$	$1,2^{4)}$	1,0	1,0
		Favourable	$\gamma_{G;inf}$	1,0	0,9	1,0	0,9	1,0
	Self-weight of the ground and (ground) water, geotechnical structures ²⁾	Unfavourable	$\gamma_{G;sup}$	1,0	1,0	1,0	1,0	1,0
		Favourable	$\gamma_{G;inf}$	1,0	1,0	1,0	1,0	1,0
Variable action	Leading	Unfavourable	$\gamma_{Q,1}$	0	$1,5 \cdot K_{FI}$	0	1,5	0
	Accompanying	Unfavourable	$\gamma_{Q,i}$	0	$1,5 \cdot \psi_0 \cdot K_{FI}$	0	$1,5 \cdot \psi_0$	0
Traffic loads Bridges	Leading	Unfavourable	$\gamma_{Q,1}$	0	$1,4 \cdot K_{FI}^{5)}$	0	$1,4^{5)}$	0
	Not leading	Unfavourable	$\gamma_{Q,i}$	0	$1,4 \cdot \psi_0 \cdot K_{FI}$	0	$1,4 \cdot \psi_0$	0
Partial factors for soil parameters see equation (2.7a)			$\gamma_M^{9)}$	M2				
Angle of shearing resistance ⁷⁾			γ_ϕ	1,2		$1,2 \cdot K_{FI}$		1,0
Effective cohesion			γ_c	1,2		$1,2 \cdot K_{FI}$		1,0
Undrained shear strength			γ_{cu}	1,8		$1,8 \cdot K_{FI}$		1,0
Unconfined strength			γ_q	1,8		$1,8 \cdot K_{FI}$		1,0
Weight density			γ	1,0		1,0		1,0
Partial factors for ground resistances see equation (2.7b)			$\gamma_R^{9)}$	R3				
Spread foundations			γ_b	–		–		–
Earth pressure and stability			$\gamma_{R,e}$	–		–		–
Coefficient applied to partial factors for strength parameters and bearing resistances of structural materials, cf DS/EN 1992 – DS/EN 1996 and DS/EN 1999			γ_0	1,0	1,0	K_{FI}	K_{FI}	$1,2 \cdot K_{FI}^{4)}$

- 1) Structural actions, which include all types of permanent self-weight: cf. clause 2.1 in DS/EN 1991-1-1.
- 2) Actions from self-weight of the ground and (ground) water interacting with the geotechnical structure as geotechnical actions, cf clause 1.5.2.1 in DS/EN 1997-1, and clause A.3.1(2)P, NOTE, in this National Annex

- 3) For traffic loads on civil engineering structures (e.g. railway and road dams, quays etc.), the partial factors for bridges apply
- 4) For bridges: $1,25 \cdot K_{FI}$ and 1,25 respectively
- 5) For heavy carriages on rails (SW/2): $1,2 \cdot K_{FI}$ and 1,2 respectively
- 6) The characteristic values of all permanent actions from one single source are to be multiplied by $\gamma_{G:sup}$ if the total resulting action effect is unfavourable, and by $\gamma_{G:inf}$, if the total resulting action effect is favourable. As an example all actions originating from the self-weight of the structure may be considered as coming from one source.
- 7) The partial factor shall be applied to $\tan \varphi$.
- 8) Reference is also made to DS/EN 1990, equations (6.10a) and (6.10b).
- 9) For the soil parameters and resistances, γ_0 is incorporated in the partial factors γ_M and γ_R .

Table A.3-2 NA Partial factors for STR/GEO design: Piles and anchors

Design approach			3					
Limit state			STR/GEO				STR	
Combination of actions			1	2	3	4	5	
Partial factors for actions see (2.6a) ⁸⁾			γ_F	A1* or A2[†]				
Permanent action ⁶⁾	Self-weight, in general ¹⁾	Unfavourable	$\gamma_{G;sup}$	$1,2 \cdot K_{FI}$ ⁴⁾	$1,0 \cdot K_{FI}$	$1,2$ ⁴⁾	1,0	1,0
		Favourable	$\gamma_{G;inf}$	1,0	0,9	1,0	0,9	1,0
	Self-weight of the ground and (ground) water, geotechnical structures ²⁾	Unfavourable	$\gamma_{G;sup}$	1,0	1,0	1,0	1,0	1,0
		Favourable	$\gamma_{G;inf}$	1,0	1,0	1,0	1,0	1,0
Variable action	Leading	Unfavourable	$\gamma_{Q,1}$	0	$1,5 \cdot K_{FI}$	0	1,5	0
	Accompanying	Unfavourable	$\gamma_{Q,i}$	0	$1,5 \cdot \psi_0 \cdot K_{FI}$	0	$1,5 \cdot \psi_0$	0
Traffic loads Bridges ³⁾	Leading	Unfavourable	$\gamma_{Q,1}$	0	$1,4 \cdot K_{FI}$ ⁵⁾	0	$1,4$ ⁵⁾	0
	Not leading	Unfavourable	$\gamma_{Q,i}$	0	$1,4 \cdot \psi_0 \cdot K_{FI}$	0	$1,4 \cdot \psi_0$	0
Partial factors for soil parameters see equation (2.7a)			γ_M ⁹⁾	M2				
Angle of shearing resistance ⁷⁾			γ_ϕ	–		–		–
Effective cohesion			γ_c	–		–		–
Undrained shear strength			γ_{cu}	–		–		–
Unconfined strength			γ_q	–		–		–
Weight density			γ_γ	1,0		1,0		1,0
Partial factors for ground resistances see equation (2.7b)			γ_R ⁹⁾	R3				
Base resistance of compression piles			γ_b	1,3		$1,3 \cdot K_{FI}$		–
Shaft resistance of compression piles			γ_s	1,3		$1,3 \cdot K_{FI}$		–
Total/combined resistance of compression piles			γ_t	1,3		$1,3 \cdot K_{FI}$		–
Shaft resistance for piles in tension.			$\gamma_{s,t}$	1,3		$1,3 \cdot K_{FI}$		–
Anchors, ultimate resistance			$\gamma_{a,ULS}$	1,3		$1,3 \cdot K_{FI}$		–
Anchors, acceptance testing			$\gamma_{a,acc,ULS}$	1,3		$1,3 \cdot K_{FI}$		–
Coefficient applied to partial factors for strength parameters and bearing resistances of structural materials, cf			γ_0	1,0	1,0	K_{FI}	K_{FI}	$1,2 \cdot K_{FI}$ ⁴⁾

DS/EN 1992 – DS/EN 1996 and DS/EN 1999						
---	--	--	--	--	--	--

1) - 9) See Table A.3-1 NA.

A.3.2 Correlation factors for pile foundations

A.3.2.1 Correlation factors ξ applied to derive characteristic values from static pile load tests

(1)P When determining the characteristic ultimate resistance, $R_{c;k}$, from values of $R_{c;m}$, measured in one or several pile load tests, allowance shall be made for the variability of the ground conditions and the effect of pile installation. The characteristic ultimate resistance should be determined as:

$$R_{c;k} = \frac{R_{c;m}}{\xi}$$

where

$\xi = 1,1$ for the actual test loaded piles

$\xi = 1,25$ for other piles where the pile loading tests are representative
cf. DS/EN 1997-1, 7.5.2 and 7.6.2.2.

A.3.2.2 Correlation factors ξ applied to derive characteristic values from soil parameters determined by geotechnical investigations

(1)P The characteristic ultimate resistance:

$$R_{c;k} = \frac{R_{c;cal}}{\xi}$$

shall be derived from design rules based on verified correlations between the results of static load tests and the results of field or laboratory tests. These design rules shall be such that the ultimate resistance when applying the characteristic value $R_{c;k}$ does not exceed the calculated or measured ultimate resistance divided by

$\xi = 1,5$, where the resistance is based on a geostatic calculation

$\xi = 1,25$ where the resistance of the pile considered has been assessed by dynamic impact test, supporting the geostatic calculation

$\xi = 1,4$ for the piles where the dynamic impact test is representative in relation to e.g. pile dimension, installation method and soil conditions.

(2)P The design rules shall be based on comparable, well-documented experience. An analytical method for determining the bearing resistance is given in Annex L of this National Annex.

(3)P The bearing resistance for bored piles shall be determined according to the limitations specified in Annex L of this National Annex.

NOTE – The resistance of CFA piles shall be determined as for bored piles.

A.3.2.3 Correlation factors ξ applied to derive characteristic values from driving resistances

(1)P The characteristic ultimate resistance:

$$R_{c;k} = \frac{R_{c;m}}{\xi}$$

shall be derived from design rules based on verified correlations between the results of static load tests and results from pile driving. These design rules shall be such that the average ultimate resistance when applying the characteristic value $R_{c;k}$ does not exceed the measured ultimate resistance divided by

$\xi = 1,5$ where the resistance is based on a pile driving formula

$\xi = 1,25$ where the resistance of the pile considered has been assessed by dynamic impact test

$\xi = 1,4$ for the piles where the dynamic impact test is representative in relation to e.g. pile dimension, installation method and soil conditions.

(2) For end-bearing piles driven into non-cohesive soil, the characteristic ultimate resistance can be determined using the "Danish Pile Driving Formula", see Annex L of this National Annex and the ξ values given.

A.3.2.4 Time effects

(1) Time effects may only be considered in the design when these have been documented on the particular construction site. The extrapolation shall be carried out by logarithmic extrapolation based on at least two measurements taken at least 7 days apart, where the first measurement shall be done at the earliest 1 day after the piling. The extrapolation may be carried no further than to 4 weeks after the initial end-of-driving, unless relevant documentation of continued resistance increment is available.

A.4 Partial factors for uplift limit state (UPL) verification

(1)P Partial factors (γ) and consequence factors (K_{FI}) are given in Tables A.4-1 NA and A.4-2 NA.

(2)P The partial factors for actions (γ_F), for soil parameters (γ_M) and for resistances (γ_R) given in Table A.4-1 NA shall be used to verify the uplift limit state (UPL), where tension elements are taken into account, or where stabilising shear stresses on the side of the structure or in vertical sections in the ground are taken into account.

Table A.4-1 NA Partial factors for UPL verification

Partial factors for actions			γ_F	Value
Permanent action	Self-weight, in general ¹⁾	Unfavourable	$\gamma_{G;dst}$	$1,1 \cdot K_{FI}$
		Favourable	$\gamma_{G;stb}$	0,9
	Self-weight of the ground and (ground) water, geotechnical structures ²⁾	Unfavourable	$\gamma_{G;dst}$	$1,1 \cdot K_{FI}$
		Favourable	$\gamma_{G;stb}$	0,9
Variable action	Leading	Unfavourable	$\gamma_{Q,1}$	$1,5 \cdot K_{FI}$
	Accompanying	Unfavourable	$\gamma_{Q,i}$	$1,5 \cdot \psi_0 \cdot K_{FI}$
Traffic loads Bridges ³⁾	Leading	Unfavourable	$\gamma_{Q,1}$	$1,4 \cdot K_{FI}^{5)}$
	Not leading	Unfavourable	$\gamma_{Q,i}$	$1,4 \cdot \psi_0 \cdot K_{FI}$
Partial factors for soil parameters			γ_M	Value
Angle of shearing resistance ⁷⁾			γ_ϕ	1,2
Effective cohesion			$\gamma_{c'}$	1,2
Undrained shear strength			γ_{cu}	1,8
Partial factors for ground resistances			γ_R	Value
Shaft resistance, piles in tension			$\gamma_{s,t}$	1,3
Anchors, ultimate resistance			$\gamma_{a;ULS}$	1,3
Anchors, acceptance testing			$\gamma_{a;acc,ULS}$	1,3

- 1) Structural actions, which include all types of permanent self-weight: cf. clause 2.1 in DS/EN 1991-1-1.
- 2) Actions from self-weight of the ground and (ground) water interacting with the geotechnical structure as geotechnical actions, cf clause 1.5.2.1 in DS/EN 1997-1, and clause A.3.1(2)P, NOTE, in this National Annex
- 3) For traffic loads on civil engineering structures (e.g. railway and road dams, quays etc.), the partial factors for bridges apply
- 5) For heavy carriages on rails (SW/2): $1,2 \cdot K_{FI}$ and 1,2 respectively
- 7) The partial factor shall be applied to $\tan \phi$.

(3) For pure buoyancy problems, i.e. structures not covered by A.4(2)P, the partial factors for actions (γ_F) given in Table A.4-2 NA can be used provided that destabilising water pressures are limited by overflow arrangements.

NOTE 1– For geotechnical structures where the self weight of structural members and water are the predominant forces, structural solutions (e.g. overflow arrangements) that will provide well-defined design assumptions associated with a relatively low design safety level should be used rather than achieving a higher design safety level together with design assumptions which are less safe. For example, to secure a structure against erosion and uplift, it will usually not be sufficient solely to apply a partial factor for the water pressure. Instead, it will be necessary to protect the structure by structural measures.

NOTE 2 – Overflow arrangements may be a combination of overflow via the top edge of or openings in walls and/or overflow via goosenecks through the floor structure. Requisite capacity with respect to quantity and distribution throughout the structure is to be ensured by the arrangement of drains and discharge elements. Overflow of water constitutes a stabilising element, and water is not to be pumped away, until the water pressures have been returned to an acceptable level.

Table A.4-2 NA Partial factors for UPL verification

- Valid solely for structures where water pressures have been limited by overflow arrangements;
- Tension elements and stabilising shear stresses shall be disregarded

Partial factors for actions			γ_F	Value
Permanent action	Self-weight, in general ¹⁾	Unfavourable	$\gamma_{G;dst}$	$1,0 \cdot K_{FI}$
		Favourable	$\gamma_{G;stb}$	1,0
	Self-weight of the ground and (ground) water, geotechnical structures ²⁾	Unfavourable	$\gamma_{G;dst}$	$1,05 \cdot K_{FI}$
		Favourable	$\gamma_{G;stb}$	1,0
Variable action,	Leading	Unfavourable	$\gamma_{Q,1}$	$1,5 \cdot K_{FI}$
	Accompanying	Unfavourable	$\gamma_{Q,i}$	$1,5 \cdot \psi_0 \cdot K_{FI}$
Traffic loads Bridges	Leading	Unfavourable	$\gamma_{Q,1}$	$1,4 \cdot K_{FI}^{5)}$
	Not leading	Unfavourable	$\gamma_{Q,i}$	$1,4 \cdot \psi_0 \cdot K_{FI}$

- 1) Structural actions, which include all types of permanent self-weight: cf. clause 2.1 in DS/EN 1991-1-1.
- 2) Actions from self-weight of the ground and (ground) water interacting with the geotechnical structure as geotechnical actions, cf. clause 1.5.2.1 in DS/EN 1997-1, and clause A.3.1(2)P, NOTE, in this National Annex
- 3) For traffic loads on civil engineering structures (e.g. railway and road dams, quays etc.), the partial factors for bridges apply
- 5) For heavy carriages on rails (SW/2): $1,2 \cdot K_{FI}$, $1,2$ respectively.

(4)P For pure buoyancy problems, the most adverse, realistic water levels as well as carefully assessed permanent self-weight are to be considered.

NOTE – The contrast to the pure buoyancy problem comprises other uplift problems such as stability analyses and design of spread foundations, where the uplift on the ground and structural elements shall be assigned to structural (STR) and geotechnical (GEO) limit states.

(5)P If a tension element has been incorporated in order to obtain static equilibrium, this tension element shall be designed to accommodate the design force needed to obtain static equilibrium.

(6)P When determining the volume of ground bonded by the tension elements (group effect), the possible distribution of available shaft resistance along the tension elements shall be taken into account, and it shall be established that the weight of the stabilising ground volume can be distributed to the group of tension elements by the required resistance of the body of soil.

(7)P The toe level of tension elements in UPL shall be determined on the basis of the critical failure mechanism.

NOTE 1 – For ground anchors, it is good engineering practice to calculate the ground volume as a truncated cone, inclined 1:2 (horizontal:vertical); for conventional bond type anchors, the truncated cone has its lower bound point at the centre of the bonded zone, as the free length only allows transfer of forces along the bond length. For the tensile test of bond type anchors, the upper limit of the apparent tendon free length L_{app} corresponds exactly to the centre of the bonded zone. Due to the recognised non-linear distribution of stabilising shear stresses along the bond length, it may be assumed on the safe side, when taking into account the group effect, that the bonding force is transmitted to the ground at the midpoint of the bonded zone. For compression type anchors, the nadir top point may refer to the distal end of the anchor, as the anchor force is shown to be transmitted to the distal end of the anchor, before it is transmitted to the ground. For a definition of bond type anchors and compression type anchors, see DS/EN 1537 and/or DS/EN ISO 22477-5.

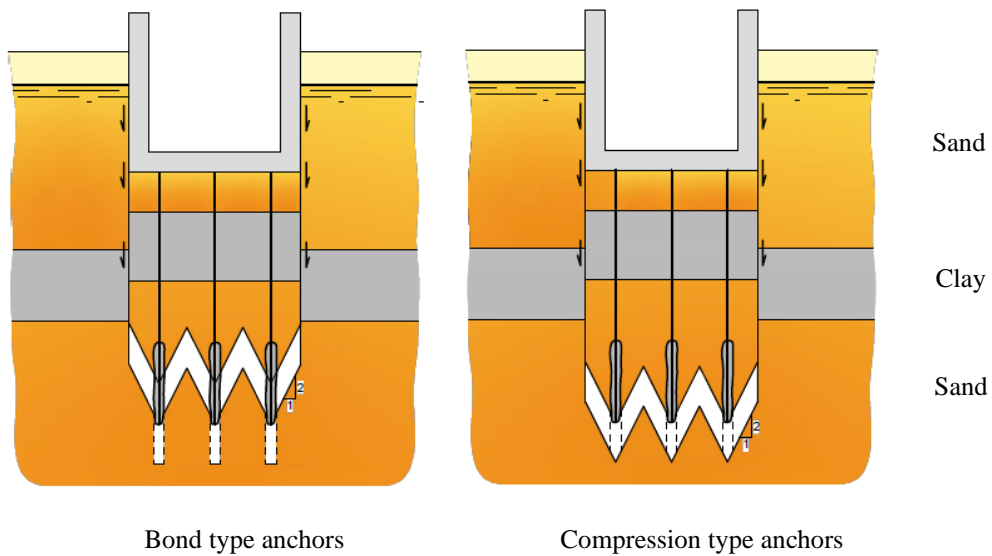

NOTE 2 – For tension piles in layered soil, a combined failure mode with lifting of the clay plug and sand layers above as a block (presuming an adequate shaft resistance in the clay layer) at the same time of extracting the piles from the underlying layer of sand will often be critical. Attention is drawn to the fact that the shaft resistance on the piles in the underlying layer of sand is reduced as a consequence of the overburden pressure relief when the block is lifted off.

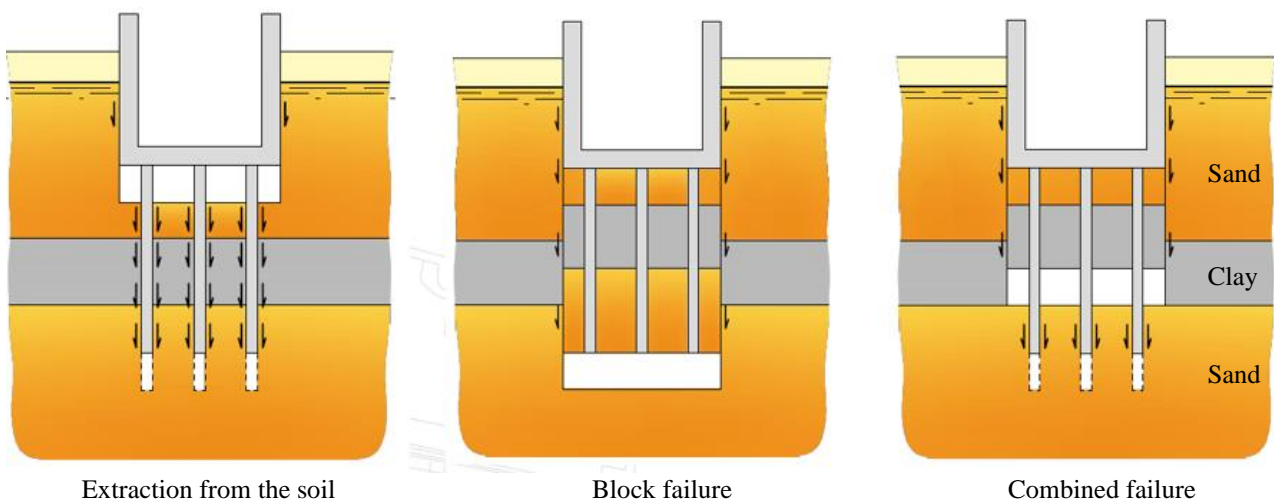

(8) Calculation of stabilising shear stresses on the sides of the structure and on vertical sections in the ground may be based on the principles of DK NA, Annex L.

A.5 Partial factors for hydraulic heave limit state (HYD) verification

(1)P For hydraulic heave limit state (HYD) verification, the partial factors for uplift (UPL) shall be applied, see A.4 of this DK NA.

(2)P According to DS/EN 1997-1, 10.4 and 10.5, safeguarding against piping and erosion requires special considerations.

A.6 Partial factors, correlation factors, limiting criteria for ultimate and serviceability limit states as well as number of investigation or suitability tests for anchors

(1)P For the verification of safety required for ground anchors, cf. equation (8.1) in persistent and transient design situations where the effect of the prestress force is investigated for the serviceability limit state, an load effect factor γ_{Serv} is applied to the maximum anchor force found, $F_{Serv;k}$:

$$F_{Serv;d} = \gamma_{Serv} \cdot F_{Serv;k}$$

Table A.6-1 NA Partial factor for the load effect of the prestress force in persistent and transient design situations

Partial factor for	Equation	Symbol	Value
Load effect of the prestress force	(8.3)	γ_{Serv}	1,0

(2) The effect of the prestress force should be determined on the basis of an interaction analysis using the stiffness of the ground, the anchors and the structure, respectively.

(3)P For the verification of anchors in ultimate limit states STR, GEO, and UPL in persistent and transient design situations, the following partial factor shall be applied:

$$- \gamma_{a;ULS} \quad \text{for } R_{ULS;k}$$

NOTE – The values to be used for $\gamma_{a;ULS}$ are given in A.3, Table A.3-2 NA, for STR/GEO and in A.4, Tables A.4-1 NA and A.4-2 NA, for UPL, in this National Annex.

(4)P For the testing of anchors for persistent and transient design situations at the ultimate limit state and for serviceability limit states, the following correlation and partial factors shall be applied:

$$- \zeta_{ULS} \quad \text{for } (R_{ULS;m})_{min}$$

$$- \gamma_{a;acc;ULS} \quad \text{for } E_{ULS;d}$$

Table A.6-2 – Values depending on the test method on anchors for persistent and transient design situations at the ultimate limit state and the serviceability limit state

Symbol	Equation	Test method ^a		
		1	2	3
ζ_{ULS}	8.6	1,1	–	–
$\gamma_{a;\text{SLS}}$	8.10	N.A.	–	–
n ^b		3 anchors /2 %	–	–
$\gamma_{a;\text{acc};\text{ULS}}$	8.13	$1,3 \cdot K_{\text{FI}}$ ^c	–	–
$\gamma_{a;\text{acc};\text{SLS}}$	8.14	N.A.	–	–
NOTE – N.A. = not applicable.				
^a For a description of the test methods, see DS/EN ISO 22477-5:2018. Test method 1 is mandatory. ^b Suitability tests shall be carried out corresponding to at least 2 % of the expected number of anchors, with a minimum of 3 anchors. Suitability tests may be upgraded to investigation tests if they are continued until failure. ^c The factor K_{FI} is applied to the partial factor $\gamma_{a;\text{acc};\text{ULS}}$ for load combinations 3 and 4 in STR/GEO.				

(5)P When carrying out investigation, suitability and acceptance tests for persistent and transient design situations at the ultimate limit state and for serviceability limit states, the anchors shall satisfy the limiting criteria given in Table A.6-3 NA.

Table A.6-3 — Limiting criteria for investigation, suitability and acceptance tests for persistent and transient design situations at the ultimate and serviceability limit states

Test method ^a	Limiting criterion	Investigation/suitability tests		Acceptance tests	
		ULS ^b (Equation 8.5)	SLS (Equation 8.8)	ULS ^b (Equation 8.13)	SLS (Equation 8.14)
1	α_1	5 mm / 2 mm	N.A.	2 mm	N.A.
2	k_1	–	–	–	–
3	α_3	–	–	–	–
NOTE – N.A. = not applicable.					
^a For a description of the test methods, see DS/EN ISO 22477-5:2018. Test method 1 is mandatory. ^b Failure (in the case of investigation tests) is defined by a vertical asymptote of a creep rate versus proof load diagram or, where such is difficult to determine, by a creep rate of 5 mm. For suitability tests where, by definition, failure is not aimed at, the criterion is a creep rate not exceeding 2 mm at extended observation time.					

(6) By long term tests (over several days), load loss measurements, ΔN , (by locked anchor), may be used as an alternative to measurements of creep by retained load, converted to equivalent creep, Δs , based on a free length corresponding to the apparent free length, L_{app} , determined from the unloading of the last load cycle before locking-off of the anchor.

NOTE 1 – Equivalent creep $\Delta s = \Delta N \cdot L_{\text{fri}} / (E_t \cdot A_t)$, where $L_{\text{fri}} = L_{\text{app}}$ and ΔN is the load loss.

NOTE 2 – For ground anchors with different free lengths, load loss measurements cannot be compared, since the load loss is dependent on the free length.

A.7 Partial factors, correlation factors and model factors for serviceability and accidental limit states verification

(1) P For the investigation of serviceability limit states and accidental limit states, partial factors $\gamma_M = 1,0$ for the strength and deformation parameters of ground and structural materials shall be used.

(2) P For piles and anchors, partial factors $\gamma_R = 1,0$ and correlation factors $\xi = 1,0$ are applied. For the effect of prestress of anchors at the serviceability limit state, however, A.6 of this National Annex applies.

(3) P Design values of actions are determined according to DS/EN 1990 DK NA (Table A1.3 DK NA).

(4) P The load combination factors, ψ_0 , ψ_1 and ψ_2 in DS/EN 1990 DK NA shall be applied, taking into account the duration of the action and the soil consolidation properties.

Annex C – Normative

C.1 Earth pressure

(1) Earth pressure on structures may be determined according to the theory of plasticity, provided that the displacements are sufficient to develop the limit state earth pressures.

NOTE – Important examples of structural types, where the displacement during failure is not necessarily sufficient to mobilise limiting values for earth pressure, are:

- Walls with internal struts (if modelled as yielding);
- Walls with large axial forces which may fail by instability or buckling;
- Unreinforced walls;
- Walls with heavily prestressed ground anchors (if modelled as yielding), particularly when there are multiple anchor levels;

(2) The partial factors of Table A.1-1 NA provide the required Danish safety for structures subject to earth pressure, when the associated analyses are based on the following:

- At the toe of the wall - where the failure surfaces from the front and back meet - a discontinuity in the failure line can occur. This corresponds to the fact that the two failure surfaces do not necessarily have coinciding rotation centres.
- The failure surface can consist of a line failure, zone failure, or a combination hereof.

(3) The roughness between the structure and the surrounding soil (the angle of shearing resistance of the wall δ and adhesion a) may normally be taken as equal to the corresponding effective strength parameters of the ground (φ' and c') unless the surface is treated with bitumen or similar products. It shall, however, be verified that the degree of roughness used in the earth pressure calculation is in accordance with the vertical equilibrium condition of the structure.

(4) When investigating the ultimate limit states, STR/GEO, the most unfavourable, realistic combination of water tables - including differential water pressure - which may occur, shall be used for the structure.

NOTE 1 – In this connection, attention is drawn to the fact that it is the water pressures on the failure surface which are governing.

NOTE 2 – Holes in the structure are usually not sufficient to prevent the build-up of a water pressure on the failure surface behind the structure.

NOTE 3 – It should be considered whether an impermeable wall may change the water table conditions, e.g. by cutting off the natural runoff, whereby a high water table behind the wall may build up.

NOTE 4 – Water pressure in cohesive soil cannot be fully documented from water table observations in stand pipes. For structures retaining cohesive soil, a water table at the top of the cohesive soil should normally be assumed, see 9.6 (3) of DS/EN 1997-1.

Annex D – Normative

Spread foundations - Analytical method for bearing resistance calculation

D.1 General

(1) The design vertical bearing resistance, R_d , of a foundation shall be assessed both for undrained and drained ultimate conditions.

(2) The effects of the following should be considered:

- the strength of the soil, generally represented by the design values of c_u , c' og φ' ;
- the eccentricity and inclination of design actions;
- the shape and depth of the foundation;
- the slope of the ground surface;
- ground water pressures and hydraulic gradients;
- the variability of the soil, especially layering.

(3) It is not possible to provide a general definition of deposits able to resist actions. Examples of deposits that may not be considered to be resisting without special measures include gyttja, peat, post-glacial clay, topsoil, uncontrolled fill, and re-excavated or frozen soil.

(4) Frost-safe depth for foundations may in DK normally be taken as 0,9 m for conventional buildings and 1,2 m for detached structures. The depth may be reduced by heating or insulation.

(5) For foundations on clay with $I_P > 15\%$, desiccation and welling may cause considerable vertical and horizontal displacements which may be counteracted by strengthening the foundation (extra foundation depth, reinforcement) and by specifying restrictions on vegetation close to the foundation.

D.2 Analytical method

D.2.1 General information regarding the analytical method

(1) The following symbols are used in Annex D.

A' = $B' \cdot L'$ the effective foundation area

B the foundation width

B' the effective foundation width

e the eccentricity of the resultant action, with subscripts B and L

H the horizontal load component, parallel to the side of width B

i the inclination factors of the load, with subscripts cohesion c , surcharge q and weight density γ

L the foundation length

L' the effective foundation length ($L' \geq B'$)

N the bearing resistance factors, with subscripts c , q and γ

q overburden or surcharge pressure at the level of the foundation base (total stresses)

q' overburden or surcharge pressure at the level of the foundation base (effective stresses)

s the shape factors of the foundation base, with subscripts c , q and γ

- V the vertical load
- δ structure-ground interface angle of shearing resistance
- φ' effective angle of shearing resistance of the soil
- c' effective cohesion of the soil
- c_u undrained shear strength of the soil
- γ' effective weight density of the soil below the foundation level.

(2) The equations for the design vertical bearing resistance specified in clauses D.2.2 and D.2.3 apply to the horizontal foundation base and ground surface, the same surface load on each side of the foundation, leading H parallel to the short side of the footing with the soil strength represented by the design values of c_u , c' , φ' and γ' , assumed constant for the ground volume governing the limit state.

(3) For non-cohesive soil the characteristic angle of shearing resistance is $\varphi'_k = \varphi'_{pl}$ (plane angle strain of shearing resistance), where the relationship between φ'_{pl} and φ'_{tr} appears from clause K.4(1) of this National Annex. For cohesive soil, φ'_k is $\sim \varphi'_{tr}$.

(4) The equations given for calculation of the bearing resistance apply to loads acting eccentrically with an eccentricity, e , not exceeding $0,30 B$.

(5) The sliding resistance of a foundation shall be investigated according to 6.5.3 in DS/EN 1997-1. If the sliding resistance is combined with other stabilising forces, e.g. from passive earth pressure, all stabilising effects shall be assessed, taking strain compatibility into account.

(6) Where sliding resistance is accounted for as the only stabilising force to the horizontal component of the design action on a foundation, and the foundation is not subjected to imposed strain from other sources, the effective angle of shearing resistance of the soil, φ' , can be taken into account instead of the critical angle of shearing resistance, cf. DS/EN 1997-1, 6.5.3 (10).

D.2.2 Undrained conditions

(1) The design resistance is calculated from:

$$R_d / A' = (\pi + 2) c_{u,d} s_c i_c + q \quad (\text{D.1})$$

with the dimensionless factors for:

- the shape of foundation:
 $s_c = 1 + 0,2(B' / L')$
- the inclination of the load, caused by a horizontal load, H :

$$i_c = \frac{1}{2} \left(1 + \sqrt{1 - \frac{H_d}{A'c_{u;d}}} \right)$$

where $H_d \leq A'c_{u;d}$

D.2.3 Drained conditions

(1) The design resistance is calculated from:

$$R_d / A' = 0,5 \gamma' B' N_\gamma s_\gamma i_\gamma + q' N_q s_q i_q + c'_d N_c s_c i_c \quad (D.2)$$

with the design values of dimensionless factors for:

- the bearing resistance:

$$N_\gamma = \frac{1}{4} \left((N_q - 1) \cos \varphi'_d \right)^{3/2} \text{ provided that } \delta \geq \varphi'_d / 2 \text{ (rough base)}$$

$$N_q = e^{\pi \tan \varphi'_d} \tan^2 (45 + \varphi'_d / 2)$$

$$N_c = (N_q - 1) \cot \varphi'_d$$

- the shape of foundation:

$$s_\gamma = 1 - 0,4 (B' / L')$$

$$s_q = s_c = 1 + 0,2 (B' / L')$$

- the inclination of the action caused by a horizontal action, H_d , parallel to the side of width B' :

$$i_\gamma = i_q^2$$

$$i_q = i_c = \left(1 - \frac{H_d}{V_d + A' c'_d \cot \varphi'_d} \right)^2$$

Appendix to Annex H - Informative

As a supplement to the provisions given in Annex H, it may be specified as guidance for conventional building structures that settlements for floors on the ground should not deviate from the settlements of the adjoining walls by more than 5 mm.

Annex K – Normative

Special conditions for geotechnical investigations and parameters

K.1 General

(1) Deposits lying below stiff, late glacial deposits, or older strata are generally characterised by good strength and deformation properties. Important exceptions are:

- late-glacial Allerød deposits;
- inter-glacial marine and marsh deposits;
- clay with slickensided fissures
- clays characterised by $I_P > 15\%$, where the exception relates to seasonal variations of water content (vegetation);
- calcareous deposits with "sinkholes" (disintegrated/dissolved by percolation of surface water).

(2) By geological evaluation of recovered soil samples, or on-site evaluation of soil deposits it shall be ensured that the ground investigation covers all significant soil layers, including in particular:

- deposits with high settlement potential, e.g. gyttja, peat, postglacial clay, topsoil or uncontrolled fill;
- clays with high swelling potential
- deposits susceptible to sliding failure.

Normally, the investigation shall be performed down to stiff late glacial deposits or older strata. If this is not possible, the investigation shall be carried out to a depth beyond which the strata have no substantial influence on the resistance to failure of the structure, or on its displacements and deformations.

K.2 Design investigations

(1) Design investigations comprise various types of geophysical surveys, mechanical explorations, test drillings or test pits with sampling, vane tests and registration of water tables, measurement of pore water pressures, pumping tests and laboratory analyses. The laboratory analyses comprise geological evaluation and soil description, classification tests and more specialised tests to determine strength and deformation properties, permeability, and geochemical properties etc. It is practical to divide design investigations into three phases:

- Site investigations, which will typically include a few separate investigation points (boreholes, CPT etc.) to give a rough estimate of the foundation conditions of a given site. At the same time, it could be investigated whether the site is contaminated. The purpose of such investigation will e.g. be to point out the most appropriate areas for placing the structure.
- Parameter investigations, which will typically be investigations to determine which kind of foundation will be appropriate for a given project. Such investigations will normally be performed to such an extent that they can form the basis for a foundation project. In case of contamination, tests from the drillings will often be analysed to estimate the environmental conditions.
- Optimisation investigations, which are usually performed to obtain an economic optimisation of a foundation project.

(2) For the extent of design investigations, reference is made to DS/EN 1997-2.

K.3 Geotechnical categories

(1) Structures of Geotechnical Category 1 shall not involve the risk of damaging neighbouring structures, sewage and supply pipes, public traffic areas etc.

(2) Spread foundations, fills and floors supported directly on the soil should only be assigned to Geotechnical Category 1 when the foundation bed consists of stiff, late glacial deposits or older deposits, which are not included in the exceptions specified in K.1.

(3) The following are examples of structures or parts of structures which may be assigned to Geotechnical Category 1:

- light buildings with a maximum design foundation load of 250 kN for spread footings and 100 kN per m for strip foundations, for which no special requirements regarding settlement conditions etc. are made;
- 0,30 m and 0,40 m thick in situ cast concrete basement walls subject to earth pressure; wall sections up to 10 m² and 15 m², when the walls are supported only by transverse walls and basement floor, respectively, and 15 m² and 20 m², respectively, when the basement wall is also restrained on top by e.g. a deck. It is assumed that the walls do not contain openings for windows or doors;
- gravity walls and retaining walls for excavations, where the retained height does not exceed 2 m;
- surcharge fills with a maximum height of 3 m;
- pipes and drainage which can be laid in accordance with standard procedures as specified in the relevant standards;
- thickness of compacted sand fills below floors not exceeding 0,6 m;
- floor slabs and pavements with layout and dimensions according to common practice without detailed design analyses;
- cuttings with inclinations not exceeding 1 vertical to 1,5 horizontal and a maximum difference in level of 4 m.

(4) The design foundation action of Geotechnical Category 2 shall not exceed 5 000 kN for spread foundations, or 1 000 kN per m strip foundation. For structures with such foundations, the design bearing pressure of the effective area is not to exceed 1 000 kN/m² in Geotechnical Category 2.

(5) Where a project, e.g. excavation, pile driving or ground water lowering, involves a risk of damaging neighbouring structures, sewage and supply lines, public traffic areas, or similar, the geotechnical investigations and calculations with regard to these neighbouring structures should at least correspond to Geotechnical Category 2, adapted to the nature, size and foundation of these structures.

(6) Where permanent damage to structures or bearing ground layers can occur without prior warning due to the absence or failure of ground water lowering or drainage systems, the structure shall be assigned to Geotechnical Category 3.

(7) Foundation on chalk with cavities and on palaeogene high plasticity clay as well as other high plasticity clays with slickensided fissures shall be analysed and assigned to Geotechnical Category 3.

NOTE – It is not uncommon that high plasticity Miocene clays contain slickensided fissures. As an exception, quaternary clays may also contain slickensided fissures.

(8) In deposits where the permeability increases with depth, excavations extending more than 3 m below the non-lowered water table shall be assigned to Geotechnical Category 3.

K.4 Geotechnical parameters

(1) For plane strain conditions, the angle of shearing resistance, ϕ'_{pl} , for sand and gravel should be determined by increasing the angle of shearing resistance determined by triaxial measurement, corresponding to $\phi'_{pl} = (1 + 0,1 I_D) \phi'_{tr}$.

NOTE – When the analytical methods are applied to determine bearing resistances of foundations according to DS/EN 1997-1 DK NA, Annex D.2, the plane strain angle of shearing resistance may be used.

(2) For unloading (e.g. excavation slopes and active earth pressure), the effective cohesion, c' , in palaeogene clays and other high to very high plasticity clays with slickensided fissures shall be taken as $c' = 0$.

NOTE 1 – Apart from the above clays and other high to very high plasticity clays with slickensided fissures, effective cohesion may be taken into account when the effective normal stress on the failure surface is positive (i.e., no tensile stresses shall be taken into account for drained conditions), as well as when assessing the effect of the unloading on the effective cohesion. Note that cracks caused by drying out cannot be handled according to above-mentioned, as the depth of the crack in this case is not controlled by the stress conditions in the soil.

NOTE 2 – The strength derived from geotechnical laboratory tests should be determined taking into account the level of strain. For triaxial tests, a level of strain from 0 to 10 % axial strain is normally applicable, while a level of strain of 0 to 15 % shear strain should be applied to shear tests (Direct Simple Shear).

Annex L – Normative

Pile foundation

L.1 Geostatic analysis

(1) For piles with the base driven into cohesive soil, the characteristic ultimate resistance can be determined based on:

$$R_{c;k} = \frac{R_{b;cal} + R_{s;cal}}{\xi} \quad \text{for compression piles}$$

$$R_{t;k} = \frac{R_{s;cal}}{\xi} \quad \text{for tension piles}$$

where

$$R_{b;cal} = 9c_u A_b \quad \text{in cohesive soil}$$

$$R_{s;cal} = \sum_{i=1}^n m r c_{ui} A_{si} \quad \text{in cohesive soil}$$

$$R_{s;cal} = \sum_{i=1}^n N_m q'_{mi} A_{si} \quad \text{in non-cohesive soil}$$

A_b effective base area

A_{si} surface area in soil layer "i"

$N_m = 0,6$ for compression piles with soil displacement
(piles of concrete, timber, closed-end steel pipes and steel sections with plugging)

$N_m = 0,3$ for compression piles with open profiles
(steel sheet piling and steel sections without plugging)

$N_m = 0,2$ for tension piles

$$m = \begin{cases} 1,0 & \text{for timber} \\ 1,0 & \text{for concrete} \\ 0,7 & \text{for steel} \end{cases}$$

c_{ui} undrained shear strength in soil layer "i"

q'_{mi} vertical effective stress at the centre of the soil layer "i"

(2) If the analyses of base resistance in cohesive soil utilise an area of the pile base which is larger than the associated contact area between the soil and structural material, the applied effective base area of the pile shall be documented.

(3) For the determination of the pile base resistance, the strength in the layers above as well as below the pile base level shall be taken into account.

(4) For driven piles with the base in hard clay till, defined by $c_u > 300$ kN/m², the following empirical expression can be used:

$$R_{b;cal} = 18 c_u A_b$$

For c_u between 150 kN/m² and 300 kN/m² linear interpolation between a factor 9 and 18 can be used.

(5) The regeneration factor, r , depends on the strength of the clay to the effect that r decreases with increasing strength. Where a direct determination is not carried out, the regeneration factor for cohesive soil may be taken as $r = 0,4$, when the strengths used in the calculations do not exceed $c_u = 500$ kN/m². For geostatic calculation of the downdrag, $r = 1,0$ shall be assumed.

(6) In the event that the piles are subjected to downdrag in a serviceability limit state, resistance contributions from the layers with downdrag shall only be taken into account in the ultimate limit state to the extent that it can be verified that the shaft resistance in these layers is mobilised in the ultimate situation.

(7) Bearing resistance contributions shall be determined taking into account the effect of any pre-drilling for driven piles, bitumen cover as well as uplift of adjacent piles during installation of driven piles.

(8) For pile groups, where pile uplift is a possibility, it shall be checked by levelling of the pile top, whether pile rebound occurs. If the rebound exceeds a limit value determined based on the settlement conditions, re-driving shall be carried out, or the base resistance shall be ignored.

(9) For piles with the base in non-cohesive soil, the geostatic calculation of the base resistance is so unreliable that it shall not be used for the final determination of the compressive resistance.

(10) For bored, in situ cast piles in soils, the bearing resistance may be considerably lower than for corresponding driven piles. A positive shaft resistance greater than 30 % of the shaft resistance of the corresponding driven pile or a design base resistance greater than 1000 kN/m² shall not be assumed, unless recognised documentation allowing a larger bearing resistance is available.

(11) Piles in limestone and chalk require special measures when assessing the bearing resistance.

NOTE – When piles are driven into limestone or chalk, the structure of these deposits may change significantly, and any potential strength recovery in the limestone/chalk may be uncertain. Consequently, the shaft resistance may be independent of previously measured in situ strengths. It may be necessary to use a combination of geostatic calculation, bearing resistance determined on the basis of driving resistance, and/or dynamic load tests correlated with static load tests.

L.2 The Danish Driving Formula

(1) For piles driven into non-cohesive soil, the characteristic ultimate compressive resistance, $R_{c;k}$, can be determined using the "Danish Pile Driving Formula".

$$R_{c;k} = R_{dyn;k} = \frac{R_{dyn;m}}{\xi}$$

where

$$R_{dyn;m} = \frac{\eta h G}{s + 0,5 s_0}$$

$$s_0 = \sqrt{\frac{2\eta h G L_p}{A E}}$$

$$\eta = \eta_0 (1 - \mu \cdot \tan \theta)$$

η efficiency factor

η_0 efficiency factor for vertical leader

μ friction coefficient between hammer and leader
($\mu \approx 0,1 - 0,4$ depending on winch, leader, hammer etc.)

θ inclination of the leader

G weight of the drop hammer

h vertical component of the drop height

s the permanent set of pile per blow

L_p pile length

A cross-sectional area of the pile

E modulus of elasticity of the pile.

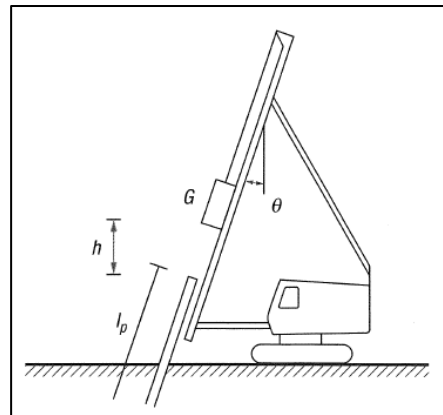

The formula assumes the use of the following values of the moduli of elasticity:

Concrete piles $E = 20 \cdot 10^6 \text{ kN/m}^2$

Timber piles $E = 10 \cdot 10^6 \text{ kN/m}^2$

Steel piles $E = 210 \cdot 10^6 \text{ kN/m}^2$

For piles shorter than 20 times the pile width, the mean value of the actual pile length and 20 times the pile width should be inserted in the pile driving formula. For timber piles, the mean diameter is used for calculating the area A . For steel piles, A is the cross-sectional area of the steel.

(2) Driving resistances are determined based on the driving result at the end of driving, or after a short driving break.

(3) In Geotechnical Category 1, the "Danish Pile Driving Formula" is allowed to be used when the pile toe is driven into competent layers.

(4) If another formula than the Danish Pile Driving Formula is applied to determine the bearing resistance of compression piles, the validity of the formula is to be based either on recognised documentation or static load tests on the same pile type, of similar length and cross-section, and in similar soil conditions.

L.3 Serviceability limit state

(1) An evaluation of the serviceability limit state for all pile foundations shall be carried out, see DS/EN 1997-1, clause 7.6.4, taking into account any downdrag and surcharge load.

NOTE – The downdrag is defined as the negative skin friction on piles and foundation sides above the level, where piles and the surrounding soil settle equally. On the safe side, this level can be chosen, corresponding to the top of the competent layers.

(2) For piles in Geotechnical Categories 1 and 2 as well as for end bearing piles transmitting the load to the ground, which can be characterised as competent in consideration of pile load and possible load from fills, the analysis of the serviceability limit state can normally be reduced to an equivalent failure calculation as follows:

$$F_{c;d} + F_{neg} \leq \frac{R_{b;cal} + R_{s;cal}}{\sqrt{\xi} \gamma_R}$$

$F_{c;d}$ design axial compression load in the ultimate limit state with the square-root of partial factors for load combination STR/GEO without contributions from downdrag

F_{neg} design downdrag of the pile using partial factor $\gamma_R = 1,0$ and correlation factor $\xi = 1,0$, determined as the lower value of the shaft resistance above the competent strata or the settlement-generating load

$R_{b;cal}, R_{s;cal}$ part of the calculated bearing resistance of the pile, originating from the competent strata below the settling strata. For piles in Geotechnical Category 1 as well as for end bearing piles, $R_{b;cal} + R_{s;cal}$ shall be replaced by $R_{dyn;m}$ minus any shaft resistance from the settling strata during driving.

ξ correlation factor according to clause A.3.2 of this National Annex

γ_R partial factor in accordance with Tables A.3-2 NA, A.4-1 NA and A.4-2 NA.

NOTE – Late glacial and older deposits are usually considered to be competent in this context. There are, however, several important exceptions – e.g. late glacial soft soil deposits, inter-glacial marine and marsh deposits as well as high and very high plasticity clays and chalk.

(3) For geostatic calculation of downdrag, the upper characteristic values of the soil strength should be applied.

NOTE – The maximum downdrag can be determined as the smaller of the two following values:

- the geostatically calculated skin friction in the deposits above the competent strata
- the settlement-generating actions within the volume, which is limited downwards by surfaces inclined 1H:2V intersecting the pile cross-section at the base of the non-settling strata. Only the part of the settlement-generating action which corresponds to the settlements that will occur in the settling strata after driving of the pile shall be taken into consideration.

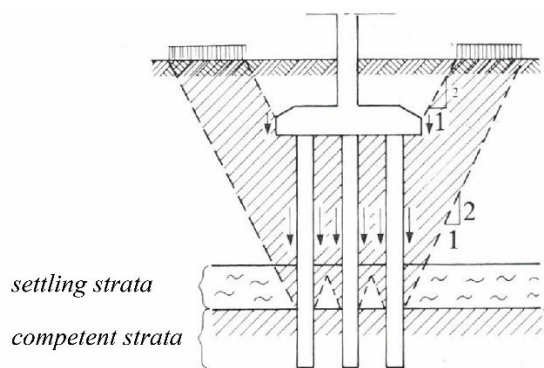

(4) By experience, downdrag may be reduced by coating the pile in and above the settling strata with bitumen. For concrete piles cast in smooth formwork and coated with 1 mm bitumen with penetration 70-100 under controlled (dry) conditions, the geostatically calculated downdrag (see above) in a serviceability limit state is assumed to be reduced to less than 10 kN per m² concrete surface. Not less than 25 % of the full value should, however, be taken into account without closer investigation due to the risk of damaging the bitumen layer during driving.

NOTE – The effect of the bitumen depends on how fast the shear stresses along the bitumen layer build up. The specified guidelines for its effect are only applicable when the stresses build up slowly in connection with the settling (or heave) of the surrounding soil, and not for shear stresses from dynamic actions (including dynamic impact pile tests).

(5) Specification of bitumen shall be according to DS/EN 12591.

L.4 Driving

(1) For all driven piles, the driving shall be recorded in a driving record containing all the relevant information about the driving (number, type, and dimension of the pile, pile rig type, hammer type, hammer weight and drop height, use of follower, ground level, toe level at the end of driving as well as notes on special conditions such as driving breaks, suspicion of a broken pile, pile head crushing etc.).

(2) Pile driving should normally be initiated by pile driving tests of approximately 5-10 % of the number of piles (but not less than 2-3 piles), recording the entire driving sequence. Test piles should be placed near the geotechnical investigation points. For the remaining piles, it is usually sufficient to record the driving sequence on the final part of the driving - typically over the last 1-2 m. When a

follower is used, the driving sequence shall be recorded both before and after the follower has been mounted.

(3) The pile shall be driven in such a way that damage is avoided.

NOTE – The risk of damaging the pile during the driving may be reduced significantly by not using a greater effective drop height ηh , or by using a smaller ratio of the hammer weight (G) to the weight of the pile (G_p) than the values given below:

	max ηh	min G/G_p
- reinforced concrete piles	approx. 1 m	approx. 0,8
- steel piles	approx. 2 m	approx. 1,5
- timber piles	approx. 4 m	approx. 1,0

(4) By »hard« driving (corresponding to $s < 0,1 s_0$) the driving shall be adjusted to avoid damaging the piling material.

(5) »Soft« driving of concrete piles, corresponding to a set $s > 0,02$ m (less than 10 blows per 0,2 m pile settlement), shall be avoided, if necessary by reducing the drop height. The requirement does not apply, if the pile penetrates partly or fully by its own weight and the weight of the hammer.